



Hangcha Europe GmbH
Mariechen-Graulich-Straße 12a,
65439 Flörsheim am Main,
Germany

Administration
Tel: 0049-61453769188
E-mail: admin@hangchaeurope.com

Sales Management
Thomas Dittrich
Mob: 0049-16096548808
E-mail: thomas.dittrich@hangchaeurope.com

Technical Support
Thomas Pannke
Mob: 0049-01759284213
E-mail: thomas.pannke@hangchaeurope.com

www.hangchaeurope.com



Follow us on
Facebook



Follow us on
YouTube



Follow us on
WeChat



Download "Hangcha
Forklift" App



ISO45001
ISO45001:2018



ISO14001
ISO14001:2015



ISO9001
ISO9001:2015



HANGCHA trucks conform
to the European Safety
Requirements.

2024 VERSION 7/COPYRIGHT: 2024/09

HANGCHA GROUP CO., LTD. reserves the right to make any changes without notice concerning colors, equipment, or specifications detailed in this brochure, or to discontinue individual models. The colors of trucks, delivered may differ slightly from those in brochures.



XC Series 3-Wheel Electric Forklift Truck With Lithium Power

with capacities of 1,300 to 2,000kg

The World of Hangcha
SINCE 1956



XC Series 3-Wheel Electric Forklift Truck With Lithium power

Covering models with a tonnage of 1.3t, 1.5t, 1.6t, 1.8t and 2.0t respectively, the new XC series three-point new energy electric forklifts are HANGCHA's dedicated-purpose battery forklifts subsequent to the XC series four-point dedicated-purpose battery forklifts.

Equipped with the dedicated lithium battery cells and modules for the XC series forklifts, which are developed jointly by HANGCHA and CATL, the truck has the features of high lifting speed, high driving speed, excellent ergonomic design, easy operation and high safety.



Excellent ergonomic design

- / The truck has a large operation space more than 50% larger than that of the traditional three-point electric truck.
- / The enlarged brake pedal and appropriate regenerative braking function can effectively reduce the driver's fatigue.
- / For the optional integrated fingertip operating system, the combined operation armrest integrates the emergency shut-off, horn and quadruple thumb switches, etc., is electrically controlled through the CAN bus, and is highly reliable.

Easy operations and maintenance

- / With the fully sealed hood and side plates, all major components including the electrically controlled components, motor, electrical components, etc. are sealed from dust and water.
- / Vulnerable parts and key parts are arranged reasonably to facilitate maintenance and repair.
- / The hood (with a self-locking gas spring) can be opened at a large angle facilitating the maintenance and replacement of the battery.

Advancement

- / The high-frequency MOSFET integrated controller ensures smooth and accurate driving and lifting control, and has excellent speed regulation performance, good performance of electronic control matching the motor, functions of regenerative braking, reverse braking and anti-sliding on ramps, etc., and high safety and reliability.
- / The ultra-high power AC drive motor has a bridge structure.
- / An ultra-high power AC oil pump motor is used. The system has high efficiency, complete protection functions, built-in speed and temperature sensors, and greatly improved reliability and life.
- / The noise can be as low as 73dBA.

Comfort

- / Owing to the low center of gravity and good stability, the driver feels comfortable during turning.
- / The intelligent sensing enables buffered descending. When the fork is 100 - 60mm away from the ground, the descending will automatically slow down, so that the goods and pallet will not hit the ground and the goods and ground can be protected effectively.
- / Silence, no pollution, energy saving and other advantages meet environmental protection requirements.
- / With friendly human-computer interfaces, the new large-screen LED instruments have good visibility and clear readings.



The dashboard in the driver's cab is placed overhead and can be seen when the driver lift her/his head, and the function buttons can be pressed easily



The packs can be easily removed by a manual or electric cart, and can be repaired and maintained conveniently

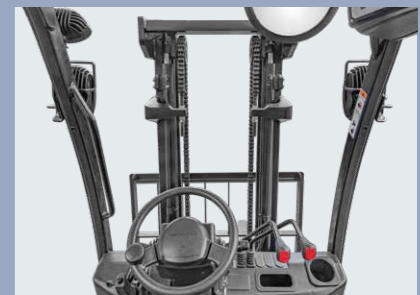

The wide-view mast with optimized design is unlikely to obstruct the operator's line of sight. The enlarged opening size of the fork carriage enables a wider view. The high fulcrum of the tilt cylinder enables better force bearing and more stable operation of the mast



The ergonomically designed tilt-adjustable small-diameter steering wheel makes the driver feel good



The seat can be adjusted back and forth by 210mm. The operator can choose the best driving position

Main Accessories

- / The main electrical components such as the motor controller, contactor, power plug, emergency cut-off switch, dashboard, accelerator, are all products of well-known foreign brands.
- / The emergency cut-off switch equipped for the standard configuration complies with European safety regulations.
- / Electronic and hydraulic overload protection devices.
- / The truck has passed the CE certification.

Standard Specification

- / Dual AC drive motors
- / High-power AC oil pump motor
- / Silent gear pump
- / Multi-function color screen instrument cluster
- / Large integral rubber pedal pad
- / Stamped iron hood, stamped iron side plates
- / Stamped stainless steel boarding step
- / Handbrake with a touch-proof mechanism
- / Turning deceleration function
- / Cloud smart module
- / Fork descending buffering
- / SPE power selection
- / Mileage display, operating time display
- / Integrated fuse box
- / DC-DC converter
- / Doublet multiway valve
- / Emergency shut-off switch
- / Reversing buzzer
- / Traction pin
- / Load sensing steering system
- / Standard duplex mast, fork, fork carriage and load backrest
- / Lithium packs with low temperature electric heating systems
- / The gas spring of the hood with a touch-proof mechanism
- / LED combination headlights, LED combination three-color tail lights
- / Charging muzzle meeting national standards



Safety

- / The optional descending lock function can disable the descending function when the driver leaves the seat, and enable high safety.
- / The standard configuration provides a fork descending buffering function. In addition, an optional electronic control function for buffering the fork's ascending is provided to protect the goods from falling and damaging the ground.
- / The handbrake can be optionally equipped with an alarm buzzer to prompt the driver to pull up the handbrake before leaving the truck.
- / Three horn buttons are provided, which are respectively on the driver's steering wheel, thumb switch equipped armrest (optional) and reverse armrest (optional), for alerting and protecting the surrounding people.
- / A PIN code should be provided before entering the system. 99 sets of PIN codes are available for the administrator. The truck is highly secured and irrelevant personnel cannot start the truck.

Options

- / Lithium packs that can be replaced quickly
- / Start with a PIN code or by swiping a card
- / Ultra-elastic solid nose tire
- / Environmentally-friendly colored solid tire
- / Left and right rearview mirrors
- / Reversing video
- / Front/rear blue lights
- / Rear operation lights
- / Cold storage truck
- / Reverse armrest (containing a horn button)
- / Fully enclosed cab
- / OPS seat sensing function
- / Fork ascending buffering
- / Triple multiway valve
- / Quadruple multiway valve
- / Quintuple multiway valve
- / Widened / heightened load backrest
- / Widened fork carriage
- / Forks of other lengths
- / Full free duplex mast
- / Full free triplex mast
- / Integrated side shifter
- / Attachments of other specifications
- / Grammer MSG531 suspended seat
- / Dedicated lithium battery charger (Titan or Schneider)
- / Integrated fingertip control system including ergonomic armrests
- / Toolbox, folder



LITHIUM POWERED

EMPOWER YOURSELF
WITH THE BEST



Li
Lithium

POWER THE POSSIBILITIES
RELIABLE LITHIUM-ION TECHNOLOGY



LITHIUM BATTERY ADVANTAGES



Long service life

4000 full charging cycles with at least 80% residual capacity.



Cold area application

Li-Ion batteries maintain high performance at temperatures below freezing.



Return on investment

Add flexibility to your operation, cost-saving in the long term, increased efficiencies.



High safety and reliability

Intelligent battery management monitoring every important function, no emission of battery gasses.



Maintenance free

No topping up of water or checking acid levels.



Opportunity charging

Full performance during several shifts thanks to effective interim charging.



High energy density

The high energy density of the Li-Ion battery ensures long working times and increases the high availability.

FEATURES & BENEFITS THE HANGCHA DIFFERENCE

Efficiency

By quick opportunity charging any downtime, such as a lunch break, can be efficiently used and the battery is recharged in a very short period of time. Interim charging does not affect the battery service life.

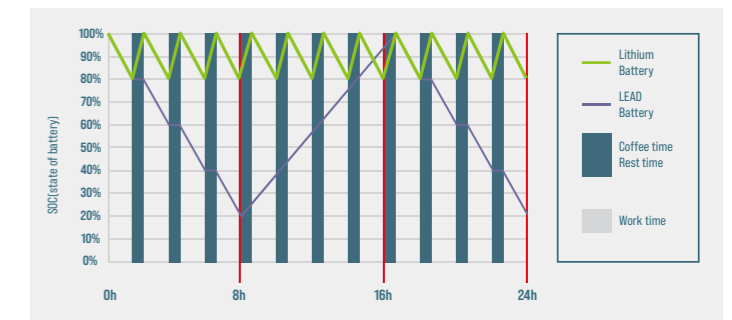

Safety

- / Intelligent battery management monitoring every important function.
- / Higher user safety, thanks to acid-free use.
- / User friendly due to avoided battery change.
- / No emission of battery gasses.

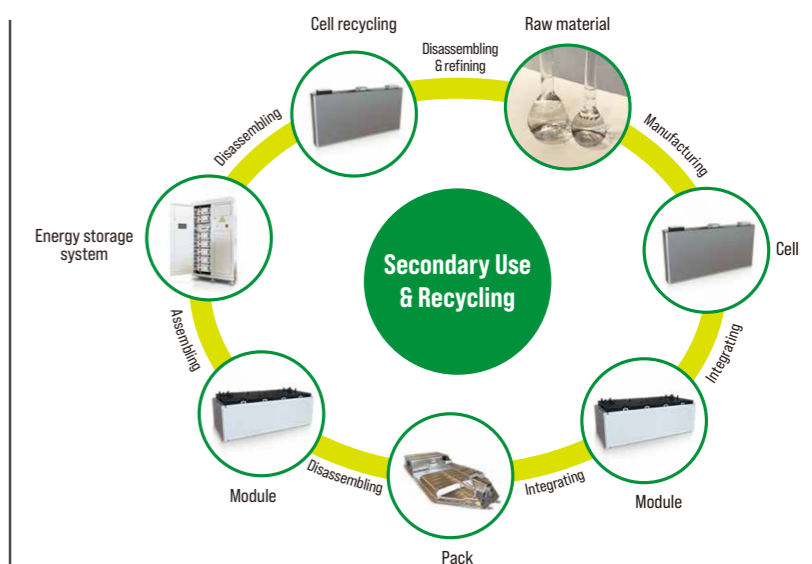

QUESTION 1

Q: What are the characteristics of lithium batteries, especially when used in high and low temperature environments?

Charging temperature: 0 C ~65 C
Discharge temperature: -30 C ~65 C
Storage environment temperature: -30 C ~60 C

After the truck key switch is closed, the instrument battery condition needs to be checked:

1. Confirm that there is no battery system alarm message on the instrument panel.
2. Please check the remaining power before use. It is recommended to use the SOC between 50% and 100%.
3. If the SOC is lower than 20%, it is not recommended to continue using it. Please charge it as soon as possible.

QUESTION 2

Q: What is the charging time and usage time calculation of forklift lithium battery?

1. Available power of lithium battery (kWh) = rated voltage × rated power × 90% (To avoid over-discharge damaging the battery, the forklift is equipped with low power protection (less than 10%)).
 2. Charging time (h) = rated capacity of lithium battery (Ah) × 90% ÷ charger output current (A).
 3. The power consumed for charging (kWh) = the available power of the lithium battery ÷ 93% (the charging efficiency of the charger is calculated as 93%).
 4. Usage time (h) = available power of lithium battery ÷ energy consumption data.
- For specific energy consumption values, please refer to the technical table on the sharing platform.**

QUESTION 3

Q: How does Hangcha BMS work to ensure the safety of the lithium battery?

HANGCHA BMS (battery management system) can monitors the cells at all time. As a result, hangcha lithium power is the reliable solution.



Battery Safety Management:

- Overcharge/over discharge protection
- Overcurrent/over-temperature/low- temperature protection
- Multi-level fault diagnosis protection
- Double fault monitoring



Battery Parameter Detection:

- Battery voltage detection and analysis
- Battery current detection and analysis
- Battery temperature detection and analysis



Equilibrium Management:

- Equalization based on voltage mode
- Equalization based on time mode
- Equalization based on battery cell SOC
- Active/passive equalization optional



Other Features:

- Low cost, low power consumption
- Historical data record
- Flexible cascade expansion
- CRC data validation

Technical data

Distinguishing mark	1.1	HANGCHA GROUP CO.,LTD.						
	1.2	Manufacturers type designation	CPDS13-XCD8G-SI CPDS13-XCC2G-SI	CPDS15-XCD8G-SI CPDS15-XCC2G-SI	CPDS16-XCD8G-SI CPDS16-XCC2G-SI	CPDS18-XCD8G-SI CPDS18-XCC2G-SI	CPDS20-XCD8G-SI CPDS20-XCC2G-SI	
1.3	Drive: electric (battery or mains), diesel, petrol, fuel gas	electric	electric	electric	electric	electric		
1.4	Operator type: hand, pedestrian, standing, seated, order-picker	seated	seated	seated	seated	seated		
1.5	Load capacity/rated load	Q (kg)	1300	1500	1600	1800	2000	
1.6	Load centre distance	c (mm)	500	500	500	500	500	
1.8	Load distance, centre of drive axle to fork	x (mm)	360	360	360	360	365	
1.9	Wheelbase	y (mm)	1277	1277	1277	1277	1407	
Weight	2.1	Service Weight	kg	2570	2770	2940	3090	3200
	2.2	Axle loading, laden front/rear	kg	3420/450	3765/505	4010/530	4315/575	4580/620
	2.3	Axle loading, unladen front/rear	kg	1185/1385	1260/1510	1340/1600	1335/1755	1365/1835
Tyres, chassis	3.1	Tyres: solid rubber, superelastic, pneumatic, polyurethane	solid	solid	solid	solid	solid	solid
	3.2	Tyre size, front	18x7 - 8	18x7 - 8	18x7 - 8	18x7 - 8	200/50-10	
	3.3	Tyre size, rear	15x4.5 - 8	15x4.5 - 8	15x4.5 - 8	15x4.5 - 8	15x4.5 - 8	
	3.5	Wheels, number front rear (x = driven wheels)	2x/2	2x/2	2x/2	2x/2	2x/2	
	3.6	Tread, front	b ₁₀ (mm)	914	914	914	914	932
	3.7	Tread, rear	b ₁₁ (mm)	178	178	178	178	178
	4.1	Tilt of mast/fork carriage forward/backward	Grad	7/6	7/6	7/6	7/6	7/6
Dimensions	4.2	Height, mast lowered	h ₁ (mm)	1978	1978	1978	1978	1978
	4.3	Free lift	h ₂ (mm)	145	145	145	145	145
	4.4	Lift	h ₃ (mm)	3000	3000	3000	3000	3000
	4.5	Height, mast extended	h ₄ (mm)	3945	3945	3945	3945	3945
	4.7	Height of overhead guard STD.	h ₆ (mm)	2100	2100	2100	2100	2100
	4.9	Seat height/stand height	h ₇ (mm)	1000	1000	1000	1000	1000
	4.12	Coupling height	h ₁₀ (mm)	520	520	520	520	520
	4.19	Overall length	l ₁ (mm)	2754	2754	2754	2754	3034
	4.20	Length to face of forks	l ₂ (mm)	1834	1834	1834	1834	1964
	4.21	Overall width	b ₁ (mm)	1080	1080	1080	1080	1149
	4.22	Fork dimensions	s/e/l (mm)	35/100/920	35/100/920	35/100/920	35/100/920	40/122/1070
	4.23	Fork carriage DIN 15 173 --- ISO 2328, class/type A,B		ISO2328 2A	ISO2328 2A	ISO2328 2A	ISO2328 2A	ISO2328 2A
	4.24	Fork-carriage width	b ₃ (mm)	1000	1000	1000	1000	1000
	4.25	Distance between fork-arms	b ₅ (mm)	200/1000	200/1000	200/1000	200/1000	240/1000
	4.31	Ground clearance, laden, below mast	m ₁ (mm)	100	100	100	100	100
4.32	Ground clearance, centre of wheelbase	m ₂ (mm)	110	110	110	110	110	
4.33	Aisle width for pallets 1000 x 1200 crossways	A _{st} (mm)	3158	3158	3158	3158	3290	
4.34	Aisle width for pallets 800 x 1200 lengthways	A _{st} (mm)	3280	3280	3280	3280	3415	
4.35	Turning radius	W _s (mm)	1470	1470	1470	1470	1600	
Performance data	5.1	Travel speed, laden/unladen	km/h	16/16	16/16	16/16	16/16	15/15
	5.2	Lift speed, laden/unladen	mm/s	450/600	450/600	450/600	430/550	400/550
	5.3	Lowering speed, laden/unladen	mm/s	460/440	460/440	460/440	460/420	470/420
	5.5	Drawbar pull, laden/unladen	N	3500 /4000	3400 /3950	3300/3900	3200/3800	3050/3700
	5.6	Max. Drawbar pull, laden/unladen	N	12000/12000	12000/12000	11600/11500	11500/11400	11200/11000
	5.7	Gradeability, laden/unladen	%	16/18	16/18	16/18	15/17	13/15
	5.8	Max. gradeability, laden/unladen	%	20/20	20/20	20/20	18/20	15/18
	5.9	Acceleration time, laden/unladen (0-10m)	s	4.5/4.1	4.6/4.2	4.7/4.3	4.8/4.4	4.9/4.5
	5.10	Service brake		Hydraulic	Hydraulic	Hydraulic	Hydraulic	Hydraulic
	5.11	Parking brake		Mechanical	Mechanical	Mechanical	Mechanical	Mechanical
Electric-engine	6.1	Drive motor rating S2 60 min	kW	5x2 AC	5x2 AC	5x2 AC	5x2 AC	5x2 AC
	6.2	Lift motor rating at S3 15%	kW	15 AC	15 AC	15 AC	15 AC	15 AC
	6.3	Battery acc. to DIN 43 531/35/36 A,B,C, no		no	no	no	no	no
	6.4	Battery voltage, nominal capacity K5	V/Ah	80/228	80/228	80/228	80/228	80/302
	6.8	Min. battery weight	kg	195	195	195	195	280
	6.9	Max. battery weight	kg	230	230	230	230	350
Addition data	8.1	Type of drive control		MOSFET/AC	MOSFET/AC	MOSFET/AC	MOSFET/AC	MOSFET/AC
		Manufacturer		XCD8G: means Inmotion controller XCC2G:means Curtis controller.				
	8.2	Operating pressure for attachments	bar	150	150	150	150	150
	8.3	Oil volume for attachments	l/min	35	35	35	35	35
	8.4	Sound level at the driver's ear according to EN / DIN 12 053	dB (A)	72	72	73	73	74
8.5	Towing coupling, type DIN		Φ24 Pin	Φ24 Pin	Φ24 Pin	Φ24 Pin	Φ24 Pin	
9.1	Hydraulic Tank - capacity (drain & refill)	liter	33	33	33	33	43	

CATL Battery Capacity	
Capacity (V/Ah)	1.3-1.8t
80/228	●
80/302	○
80/375	○

Note: ● Standard battery capacity; ○ Optional battery capacity

Technical data(Permanent magnet synchronous)

Distinguishing mark	1.1	HANGCHA GROUP CO.,LTD.						
	1.2	Manufacturers type designation	CPDS13-XCY2G-SI	CPDS15-XCY2G-SI	CPDS16-XCY2G-SI	CPDS18-XCY2G-SI	CPDS20-XCY2G-SI	
1.3	Drive: electric (battery or mains), diesel, petrol, fuel gas	electric	electric	electric	electric	electric		
1.4	Operator type: hand, pedestrian, standing, seated, order-picker	seated	seated	seated	seated	seated		
1.5	Load capacity/rated load	Q (kg)	1300	1500	1600	1800	2000	
1.6	Load centre distance	c (mm)	500	500	500	500	500	
1.8	Load distance, centre of drive axle to fork	x (mm)	360	360	360	360	365	
1.9	Wheelbase	y (mm)	1277	1277	1277	1277	1407	
Weight	2.1	Service Weight	kg	2570	2770	2940	3090	3200
	2.2	Axle loading, laden front/rear	kg	3420/450	3765/505	4010/530	4315/575	4580/620
	2.3	Axle loading, unladen front/rear	kg	1185/1385	1260/1510	1340/1600	1335/1755	1365/1835
Tyres, chassis	3.1	Tyres: solid rubber, superelastic, pneumatic, polyurethane	solid	solid	solid	solid	solid	solid
	3.2	Tyre size, front	18x7 - 8	18x7 - 8	18x7 - 8	18x7 - 8	200/50 - 10	
	3.3	Tyre size, rear	15x4.5 - 8	15x4.5 - 8	15x4.5 - 8	15x4.5 - 8	15x4.5 - 8	
	3.5	Wheels, number front rear (x = driven wheels)	2x/2	2x/2	2x/2	2x/2	2x/2	
	3.6	Tread, front	b ₁₀ (mm)	914	914	914	914	932
	3.7	Tread, rear	b ₁₁ (mm)	178	178	178	178	178
	4.1	Tilt of mast/fork carriage forward/backward	Grad	7/6	7/6	7/6	7/6	7/6
Dimensions	4.2	Height, mast lowered	h ₁ (mm)	1978	1978	1978	1978	1978
	4.3	Free lift	h ₂ (mm)	145	145	145	145	145
	4.4	Lift	h ₃ (mm)	3000	3000	3000	3000	3000
	4.5	Height, mast extended	h ₄ (mm)	3945	3945	3945	3945	3945
	4.7	Height of overhead guard STD.	h ₆ (mm)	2100	2100	2100	2100	2100
	4.9	Seat height/stand height	h ₇ (mm)	1000	1000	1000	1000	1000
	4.12	Coupling height	h ₁₀ (mm)	520	520	520	520	520
	4.19	Overall length	l ₁ (mm)	2754	2754	2754	2754	3034
	4.20	Length to face of forks	l ₂ (mm)	1834	1834	1834	1834	1964
	4.21	Overall width	b ₁ (mm)	1080	1080	1080	1080	1149
	4.22	Fork dimensions	s/e/l (mm)	35/100/920	35/100/920	35/100/920	35/100/920	40/122/1070
	4.23	Fork carriage DIN 15 173 --- ISO 2328, class/type A,B		ISO2328 2A	ISO2328 2A	ISO2328 2A	ISO2328 2A	ISO2328 2A
	4.24	Fork-carriage width	b ₃ (mm)	1000	1000	1000	1000	1000
	4.25	Distance between fork-arms	b ₅ (mm)	200/1000	200/1000	200/1000	200/1000	240/1000
	4.31	Ground clearance, laden, below mast	m ₁ (mm)	100	100	100	100	100
4.32	Ground clearance, centre of wheelbase	m ₂ (mm)	110	110	110	110	110	
4.33	Aisle width for pallets 1000 x 1200 crossways	A _{st} (mm)	3158	3158	3158	3158	3290	
4.34	Aisle width for pallets 800 x 1200 crossways	A _{st} (mm)	3280	3280	3280	3280	3415	
4.35	Turning radius	W _s (mm)	1470	1470	1470	1470	1600	
Performance data	5.1	Travel speed, laden/unladen	km/h	16/16	16/16	16/16	16/16	15/15
	5.2	Lift speed, laden/unladen	mm/s	450/600	450/600	450/600	430/550	400/550
	5.3	Lowering speed, laden/unladen	mm/s	460/440	460/440	460/440	460/420	470/420
	5.5	Drawbar pull, laden/unladen	N	3500 /4000	3400 /3950	3300/3900	3200/3800	3050/3700
	5.6	Max. Drawbar pull, laden/unladen	N	12000/12000	12000/12000	11600/11500	11500/11400	11200/11000
	5.7	Gradeability, laden/unladen	%	16/18	16/18	16/18	15/17	13/15
	5.8	Max. gradeability, laden/unladen	%	20/20	20/20	20/20	18/20	15/18
	5.9	Acceleration time, laden/unladen (0-10m)	s	4.5/4.1	4.6/4.2	4.7/4.3	4.8/4.4	4.9/4.5
	5.10	Service brake		Hydraulic	Hydraulic	Hydraulic	Hydraulic	Hydraulic
	5.11	Parking brake		Mechanical	Mechanical	Mechanical	Mechanical	Mechanical
Electric-engine	6.1	Drive motor rating S2 60 min	kW	5x2 AC	5x2 AC	5x2 AC	5x2 AC	5x2 AC
	6.2	Lift motor rating at S3 15%	kW	11AC	11AC	11AC	11AC	11AC
	6.3	Battery acc. to DIN 43 531/35/36 A,B,C, no		no	no	no	no	no
	6.4	Battery voltage, nominal capacity K5	V/Ah	80/230	80/230	80/230	80/230	80/230
	6.8	Min. battery weight	kg	195	195	195	195	280
	6.9	Max. battery weight	kg	230	230	230	230	350
Addition data	8.1	Type of drive control		MOSFET/AC	MOSFET/AC	MOSFET/AC	MOSFET/AC	MOSFET/AC
		Manufacturer		XC2G:means Empower controller.				
	8.2	Operating pressure for attachments	bar	150	150	150	150	150
	8.3	Oil volume for attachments	l/min	35	35	35	35	35
	8.4	Sound level at the driver's ear according to EN / DIN 12 053	dB (A)	72	72	73	73	74
8.5	Towing coupling, type DIN		Φ24 Pin	Φ24 Pin	Φ24 Pin	Φ24 Pin	Φ24 Pin	
9.1	Hydraulic Tank - capacity (drain & refill)	liter	33	33	33	33	43	

EVE Battery Capacity(Permanent magnet synchronous)			
Capacity (V/Ah)	1.3-1.5t	1.6-1.8t	2.0t
80/230	●	●	●
80/304	○	○	○
80/460	/	/	○

Note: ● Standard battery capacity; ○ Optional battery capacity; / Not available

CATL Battery Capacity(Permanent magnet synchronous)			
Capacity (V/Ah)	1.3-1.5t	1.6-1.8t	2.0t
80/228	○	○	/
80/302	○	○	○
80/375	/	/	○

Note: ● Standard battery capacity; ○ Optional battery capacity; / Not available

XC Series 3-Wheel Electric Forklift Truck With Lithium Power Mast Specification

Type	Model	Lifting height mm	Lowered overall height mm	Overall height		Free lifting height		Tilt range		Capacity				
				With backrest	Without backrest	With backrest	Without backrest	F	R	Load center@500mm				
				mm	mm	mm	mm	(°)	(°)	1.3t	1.5t	1.6t	1.8t	2.0t
2-stage wide view mast	M250	2500	1738	3445	3060	140	140	7	6	1300	1500	1600	1800	2000
	M270	2700	1838	3645	3260	140	140	7	6	1300	1500	1600	1800	2000
	M300	3000	1988	3945	3560	140	140	7	6	1300	1500	1600	1800	2000
	M330	3300	2138	4245	3860	140	140	7	6	1300	1500	1600	1800	2000
	M350	3500	2238	4445	4060	140	140	7	6	1300	1500	1600	1800	2000
	M360	3600	2338	4545	4160	140	140	7	6	1300	1500	1600	1800	2000
	M400	4000	2588	4945	4560	140	140	7	6	1300	1500	1600	1800	2000
	M430	4300	2738	5245	4860	140	140	7	6	1200	1400	1500	1700	1900
	M450	4500	2838	5445	5060	140	140	7	6	1100	1300	1400	1600	1800
	2-stage full-free lifting mast	U250	2500	1738	3445	3060.5	793	1090	7	6	1300	1500	1600	1800
U270		2700	1838	3645	3260.5	893	1190	7	6	1300	1500	1600	1800	2000
U300		3000	1988	3945	3560.5	1043	1340	7	6	1300	1500	1600	1800	2000
U330		3300	2138	4245	3860.5	1193	1490	7	6	1300	1500	1600	1800	2000
U350		3500	2238	4445	4060.5	1293	1590	7	6	1300	1500	1600	1800	2000
U360		3600	2288	4545	4160.5	1343	1640	7	6	1300	1500	1600	1800	2000
U400		4000	2538	4945	4560.5	1593	1940	7	6	1300	1500	1600	1800	2000
N400		4000	1888	4955	4552	943	1292	3.5	5	1300	1500	1600	1800	2000
N430		4300	1988	5255	4852	1043	1392	3.5	5	1200	1400	1500	1700	1900
N450		4500	2038	5455	5052	1093	1392	3.5	5	1100	1300	1400	1600	1800
3-stage full-free lifting mast	N470	4700	2113	5655	5252	1168	1492	3.5	5	1000	1200	1300	1500	1700
	N480	4800	2138	5755	5352	1193	1492	3.5	5	1000	1200	1300	1500	1700
	N500	5000	2213	5955	5552	1268	1592	3.5	5	900	1100	1200	1400	1600
	N550	5500	2388	6455	6052	1443	1792	3.5	5	800	1000	1100	1250	1500
	N600	6000	2588	6955	6552	1643	1992	3.5	5	700	900	1000	1100	1300
	N650	6500	2788	7455	7052	1843	2192	3.5	5	530	730	800	950	1100

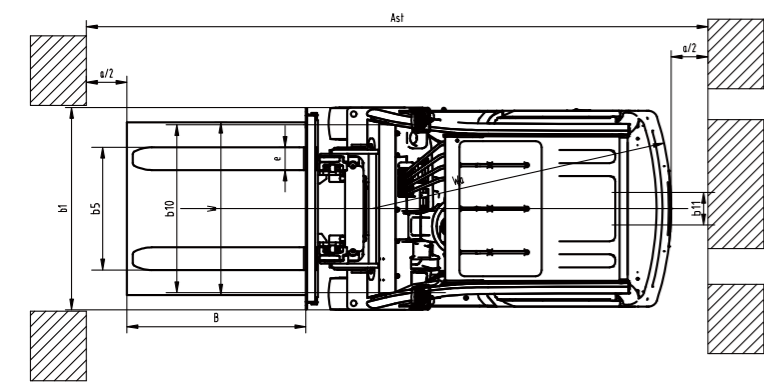
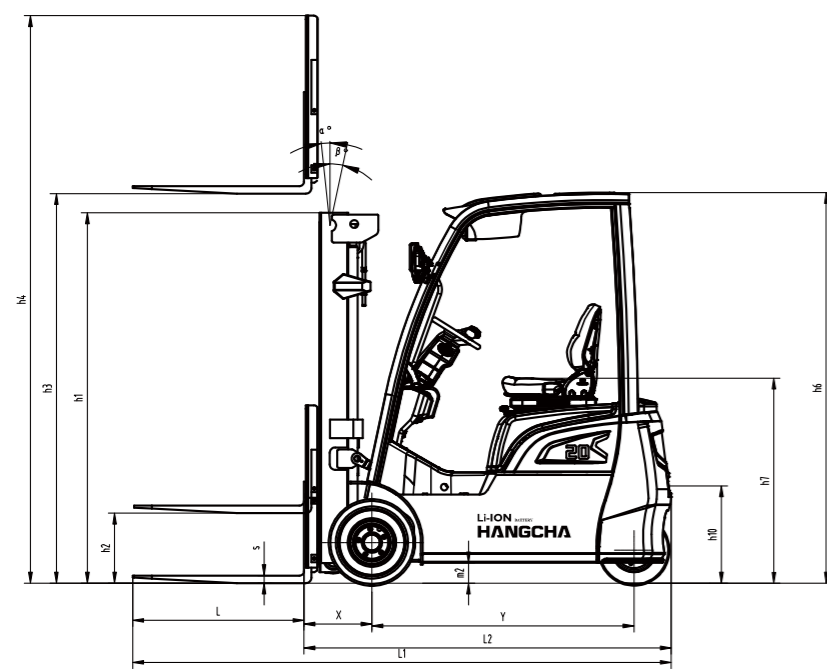

a=200mm
 $AST = a + Wa + \sqrt{(X+B)^2 + (W/2)^2}$

